



MHR SERIES

Miniature General Purpose AC LVDT

SPECIFICATIONS

- ◆ Small size and low mass core
- ◆ High output signal
- ◆ Stroke ranges from ± 0.005 to ± 2 inches
- ◆ AC operation from 2kHz to 20kHz
- ◆ Stainless steel housing
- ◆ Imperial or metric threaded core

The legendary **MHR Series** LVDTs provide precision measurements in space restrictive applications. With a diameter of just 3/8 inch [9.5mm], and an extremely lightweight core, the MHR Series is ideal for applications where excessive core weight could influence the motion; with less inertia, accurate measurements at higher displacement speeds are easier to achieve. The lightweight core also reduces mechanical stresses and helps preserve the structural integrity of the core actuation assembly.

The high output sensitivity resulting from the close electrical coupling between the coil and core provides ample signal for interfacing with practically all signal conditioners and conditioning circuits. The magnetic stainless steel housing provides electromagnetic and electrostatic shielding.

The high temperature operation (200°C) model, MHR-T is available for stroke ranges of ± 0.025 to ± 1 inch. A High pressure (vented case) model, MHR-V is also available. The MHR is compatible with the full line of Measurement Specialties LVDT signal conditioners.

Like in most of our LVDTs, the MHR windings are vacuum impregnated with a specially formulated, high temperature, flexible resin, and the coil assembly is potted inside its housing with a two-component epoxy. This provides excellent protection against hostile environments such as high humidity, vibration and shock.

FEATURES

- ◆ Compact size
- ◆ Lightweight core
- ◆ $\pm 0.25\%$ linearity (100% stroke)
- ◆ Shock and vibration tolerant
- ◆ Stainless steel case
- ◆ Calibration certificate supplied with each unit

APPLICATIONS

- ◆ X, Y, Z stage position feedback
- ◆ Wire-die bonding machines
- ◆ Cylinder position feedback
- ◆ Voice coil testing
- ◆ Materials testing machines
- ◆ Space restricted installations

PERFORMANCE SPECIFICATIONS

ELECTRICAL SPECIFICATIONS (common)	
Input voltage	3 VRMS sine wave
Input frequency	2kHz to 20kHz
Test frequency	2.5kHz (standard)

ELECTRICAL SPECIFICATIONS @ 10kHz (recommended operation)									
Parameter	MHR 005	MHR 010	MHR 025	MHR 050	MHR 100	MHR 250	MHR 500	MHR 1000	MHR 2000
Stroke range	±0.005 [±0.13]	±0.010 [±0.25]	±0.025 [±0.64]	±0.05 [±1.27]	±0.10 [±2.54]	±0.25 [±6.35]	±0.5 [±12.7]	±1 [±25.4]	±2 [±50.8]
Sensitivity V/V/inch [mV/V/mm]	8.70 [343]	6.05 [238]	8.10 [319]	3.15 [124]	2.80 [110]	2.07 [81.5]	1.96 [77.2]	0.77 [30.3]	0.49 [19.3]
Output at stroke ends mV/V (*)	43.5	60.5	202.5	157.5	280	517.5	980	770	980
Phase shift	+38°	+20°	+21°	+8°	+5°	+7°	+7°	-1°	-15°
Input impedance (PRIMARY)	84Ω	165Ω	238Ω	419Ω	400Ω	345Ω	264Ω	155Ω	504Ω
Output impedance (SECONDARY)	302Ω	300Ω	485Ω	154Ω	200Ω	420Ω	810Ω	450Ω	1780Ω
Non-linearity	±% of FR								
@ 50% stroke	0.20	0.10	0.15	0.15	0.15	0.15	0.15	0.20	/
@100% stroke (max)	0.25	0.25	0.25	0.25	0.25	0.25	0.25	0.25	0.50
@125% stroke	0.30	0.35	0.25	0.35	0.25	0.35	0.30 (**)	0.50	/
@150% stroke	0.40	0.35	0.30	0.50	0.30	0.50 (**)	0.75 (**)	/	/
Null voltage (max.)	2.5% FRO	1.0% FRO	0.5% of FRO						

ELECTRICAL SPECIFICATIONS @ 2.5kHz (standard calibration)									
Parameter	MHR 005	MHR 010	MHR 025	MHR 050	MHR 100	MHR 250	MHR 500	MHR 1000	MHR 2000
Stroke range	±0.005 [±0.13]	±0.010 [±0.25]	±0.025 [±0.64]	±0.05 [±1.27]	±0.10 [±2.54]	±0.25 [±6.35]	±0.5 [±12.7]	±1 [±25.4]	±2 [±50.8]
Sensitivity V/V/in [mV/V/mm]	3.19 [126]	3.36 [132]	4.36 [172]	2.55 [100]	2.40 [94]	1.73 [68]	1.60 [63]	0.70 [27]	0.47 [19]
Output at stroke ends, mV/V (*)	16	33.6	109	127.5	240	432.5	800	700	940
Phase shift	+73°	+59°	+58°	+36°	+30°	+33°	+23°	+6°	+3°
Input impedance (PRIMARY)	59Ω	78Ω	116Ω	141Ω	135Ω	147Ω	145Ω	100Ω	304Ω
Output impedance (SECONDARY)	260Ω	192Ω	286Ω	90Ω	125Ω	268Ω	445Ω	370Ω	13620Ω
Non-linearity	±% of FR								
@ 50% stroke	0.20	0.10	0.15	0.15	0.15	0.15	0.15	0.20	/
@100% stroke (max)	0.25	0.25	0.25	0.25	0.25	0.25	0.25	0.25	0.25
@125% stroke	0.30	0.35	0.25	0.35	0.25	0.35	0.30 (**)	0.50	/
@150% stroke	0.40	0.35	0.30	0.50	0.30	0.50 (**)	0.75 (**)	/	/
Null voltage (max)	3% FRO	1.5% FRO	0.5% of FRO						

(*) Unit for output at stroke ends is millivolt per volt of input voltage

(**) Requires special reduced core length

MHR SERIES

Miniature General Purpose AC LVDT

ENVIRONMENTAL SPECIFICATIONS & MATERIALS	
Operating temperature	-65°F to +300°F [-55°C to 150°C]
Shock survival	1,000 g (11ms half-sine)
Vibration tolerance	20 g up to 2KHz
Housing material	AISI 400 Series stainless steel
Electrical connection	Six lead-wires, 32 AWG stranded Copper, PTFE insulated, 1 foot [0.3m] long (<i>longer wires optional</i>)
IEC 60529 rating	IP61

Notes:

All values are nominal unless otherwise noted

Electrical specifications are for the test frequency indicated in the table

Dimensions are in inch [mm] unless otherwise noted

FR: Full Range is the stroke range, end to end; FR=2xS for ±S stroke range

FRO (Full Range Output): Algebraic difference in outputs measured at the ends of the range

MECHANICAL SPECIFICATIONS

Parameter	MHR 005	MHR 010	MHR 025	MHR 050	MHR 100	MHR 250	MHR 500	MHR 1000	MHR 2000
Body length "A"	0.375 [9.5]	0.535 [13.6]	0.660 [16.8]	0.815 [20.7]	0.990 [25.1]	1.850 [47.0]	3.300 [83.82]	5.600 [142.2]	8.000 [203.2]
Core length "B"	0.180 [4.6]	0.233 [5.9]	0.400 [10.2]	0.500 [12.7]	0.625 [15.9]	1.125 [28.6]	2.000 [50.8]	3.000 [76.2]	3.00 [76.2]
Body weight oz [g]	0.07 [2]	0.11 [3]	0.18 [5]	0.21 [6]	0.21 [6]	0.32 [9]	0.60 [17]	0.92 [26]	1.4 [40]
Core weight oz [g]	0.004 [0.1]	0.007 [0.2]	0.016 [0.5]	0.016 [0.5]	0.025 [0.7]	0.032 [0.9]	0.056 [1.6]	0.088 [2.5]	0.088 [2.5]

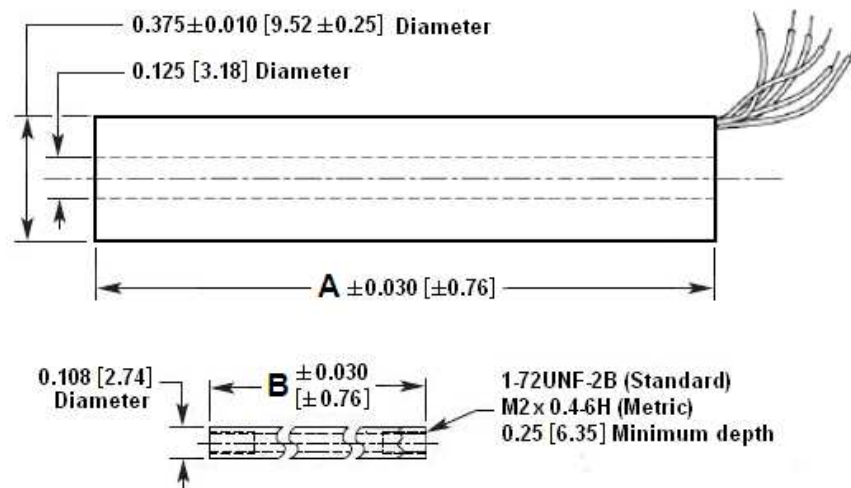

Dimensions are in inch [mm]

MHR SERIES

Miniature General Purpose AC LVDT

WIRING INFORMATION

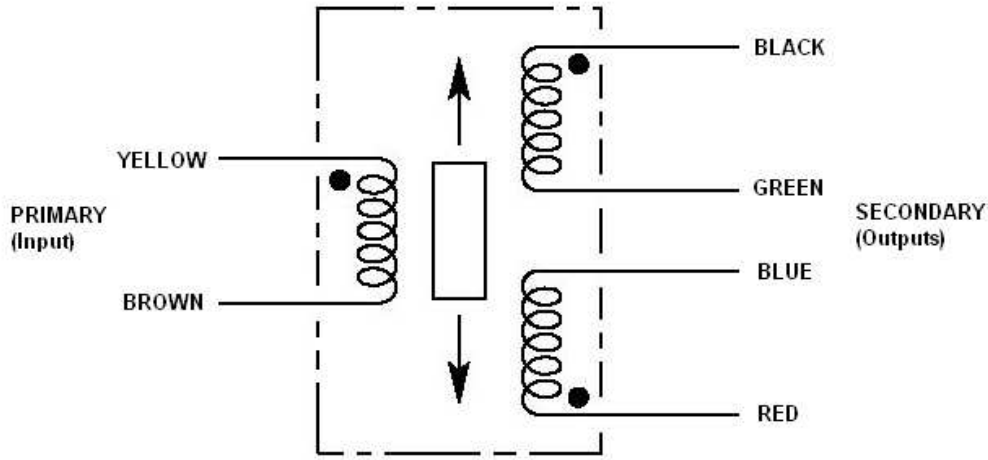

Connect Blue to Green for differential output

ORDERING INFORMATION

Description	Model	Part Number
±0.005 inch LVDT	MHR 005	02560405-000
±0.010 inch LVDT	MHR 010	02560406-000
±0.025 inch LVDT	MHR 025	02560407-000
±0.05 inch LVDT	MHR 050	02560408-000
±0.10 inch LVDT	MHR 100	02560409-000

Description	Model	Part Number
±0.25 inch LVDT	MHR 250	02560410-000
±0.5 inch LVDT	MHR 500	02560411-000
±1 inch LVDT	MHR 1000	02560412-000
±2 inch LVDT	MHR 2000	02561033-000

OPTIONS		
5.0 kHz calibration		XXXXXXXX-002
10 kHz calibration		XXXXXXXX-003
Metric threaded core		XXXXXXXX-006
10 foot long lead-wires	Consult factory	XXXXXXXX-040

Note: Add multiple option dash numbers together to determine proper ordering suffix

Example: MHR 1000, ±1 inch, with 5 kHz calibration and metric threaded core, P/N 02560412-008

ACCESSORIES	
Core connecting rod, 6 inches long, 1-72 threads	05282945-006
Core connecting rod, 12 inches long, 1-72 threads	05282945-012
Core connecting rod, 24 inches long, 1-72 threads	05282945-024
Core connecting rod, 36 inches long, 1-72 threads	05282945-036
Core connecting rod, 6 inches long, M2x0.4 metric threads	05282976-006
Core connecting rod, 12 inches long, M2x0.4 metric threads	05282976-012
Mounting block	04560954-000

广州工控传感科技有限公司

电话: 400-822-6658

邮箱: gzgk@foxmail.com

网址: www.gkmems.com

地址: 广州市天河区珠江西路15号16层