



DP86

Differential Pressure Sensor

SPECIFICATIONS

- 316L SS
- Wet/Wet Differential
- Low Pressure

The DP86 differential pressure sensor is a double-sided, media compatible, piezoresistive silicon pressure sensor packaged in a 316L stainless steel housing designed for O-ring mounting applications. The sensing package utilizes silicone oil to transfer pressure from the two 316L stainless steel diaphragms to a single sensing element.

The DP86 is designed for high performance, low pressure applications where differential pressure measurement is required. The stainless steel package makes it suitable for use in liquids and corrosive environments.

Please refer to the DP86 uncompensated, non-silicone oil, constant current and constant voltage (fittings and cable design) for more information on different features of the DP86.

Features

- O-Ring Mount
- Up to -40°C to +125°C Operating Range
- Up to $\pm 0.1\%$ Pressure Non-Linearity
- Solid State Reliability
- Low Pressure

Applications

- Level Controls
- Tank Level Measurement
- OEM Equipment
- Corrosive Fluids and Gas Measurement Systems
- Flow Measurements

DP86

Differential Pressure Sensor

Specifications

Unless otherwise specified, Supply Current: 1.5mA; Ambient Temperature: 25°C

PARAMETERS	001PSI			005PSI			≥015PSI			UNITS	NOTES
	MIN	TYP	MAX	MIN	TYP	MAX	MIN	TYP	MAX		
Sensitivity	9.0		20.0	12.5	19.5	26.5	13.2	20	26.5	mV/V@FS	
Zero Pressure Output	-4.0		8.0	-6.0		8.0	-6.0		8.0	mV/V	1
Pressure Non-Linearity	-0.30		0.30	-0.20		0.20	-0.10		0.10	%Span	2
Pressure Hysteresis	-0.10		0.10	-0.10		0.10	-0.05		0.05	%Span	
Input/Output Resistance	4.4		6.2	3.8	4.4	5.8	3.8	4.4	5.8	kΩ	
Temp. Coefficient – Span	-3150	-	-2150	-1650	-1250	-1000	-1450	-1250	-1000	ppm/°C	3
		2450									
Temp. Coefficient – Offset		1			1			1		μV/V/°C	3
Temp. Coefficient – Resistance	2600	3200	3500	1300	1510	1750	1300	1510	1750	ppm/°C	3
Thermal Hysteresis – Span	-0.25		0.25	-0.25		0.25	-0.25		0.25	%Span	3
Thermal Hysteresis – Offset	-0.25		0.25	-0.25		0.25	-0.25		0.25	%Span	3
Line (Common Mode) Pressure			1000			1000			1000	psi	
Line Pressure Effect on Zero			3.0			0.8			0.5	%Span/1kpsi %Span/175psi	
Pressure Overload			10X			3X			3X	Rated	4
Pressure Burst			12X			4X			4X	Rated	5
Operating Temperature	-40		+85	-40		+125	-40		+125	°C	6
Storage Temperature	-40		+125	-40		+125	-40		+125	°C	6
Vibration (10~2000Hz)			20			20			20	g	
Insulation Resistance (50V _{DC})	50			50			50			MΩ	7
Output Load Resistance	5			5			5			MΩ	8
Supply Voltage		5.0	12.0		5.0	9.5		5	9.5	V	
Supply Current			2.0			1.5			1.5	mA	
Voltage Breakdown			500			500			500	V _{RMS}	9
Endurance (FS @ 25°C)						1,000,000				Cycles	

Media Compatibility – Pressure Port

All fluids and gases compatible with 316L Stainless Steel & Nitrile

Notes

1. Measured at ambient pressure.
2. Best fit straight line
3. Over the temperature range -20°C to +85°C (0°C to 50°C for 1psi, 0°C to 70°C for 5psi) with respect to 25°C.
4. For high-end port, rated or 1000psi whichever is less; for low-end port, rated or 150psi whichever is less. The maximum pressure that can be applied without changing the transducer's performance or accuracy.
5. The maximum pressure that can be applied to a transducer without rupture of either the sensing element or transducer.
6. Temperature range for cable and connector is -20°C to +105°C.
7. Between case and sensing element.
8. Load resistance to reduce measurement errors due to output loading.
9. At dry air.
10. Direct mechanical contact with diaphragm is prohibited. Diaphragm surface must remain free of defects (scratches, punctures, fingerprints, etc.) for device to operate properly. Caution is advised when handling parts with exposed diaphragms. Use protective cap whenever devices are not in use.
11. Shipping:
The Stainless Steel diaphragm is protected by a static dissipative cap, each unit is packaged individually in a 2.5" plastic vial with antistatic foam, cable assembly included in vial.
12. Marking:
Device is identified with model number with Pressure Range, Type, Lot Number, Serial Number and Date Code.

DP86

Differential Pressure Sensor

Dimensions

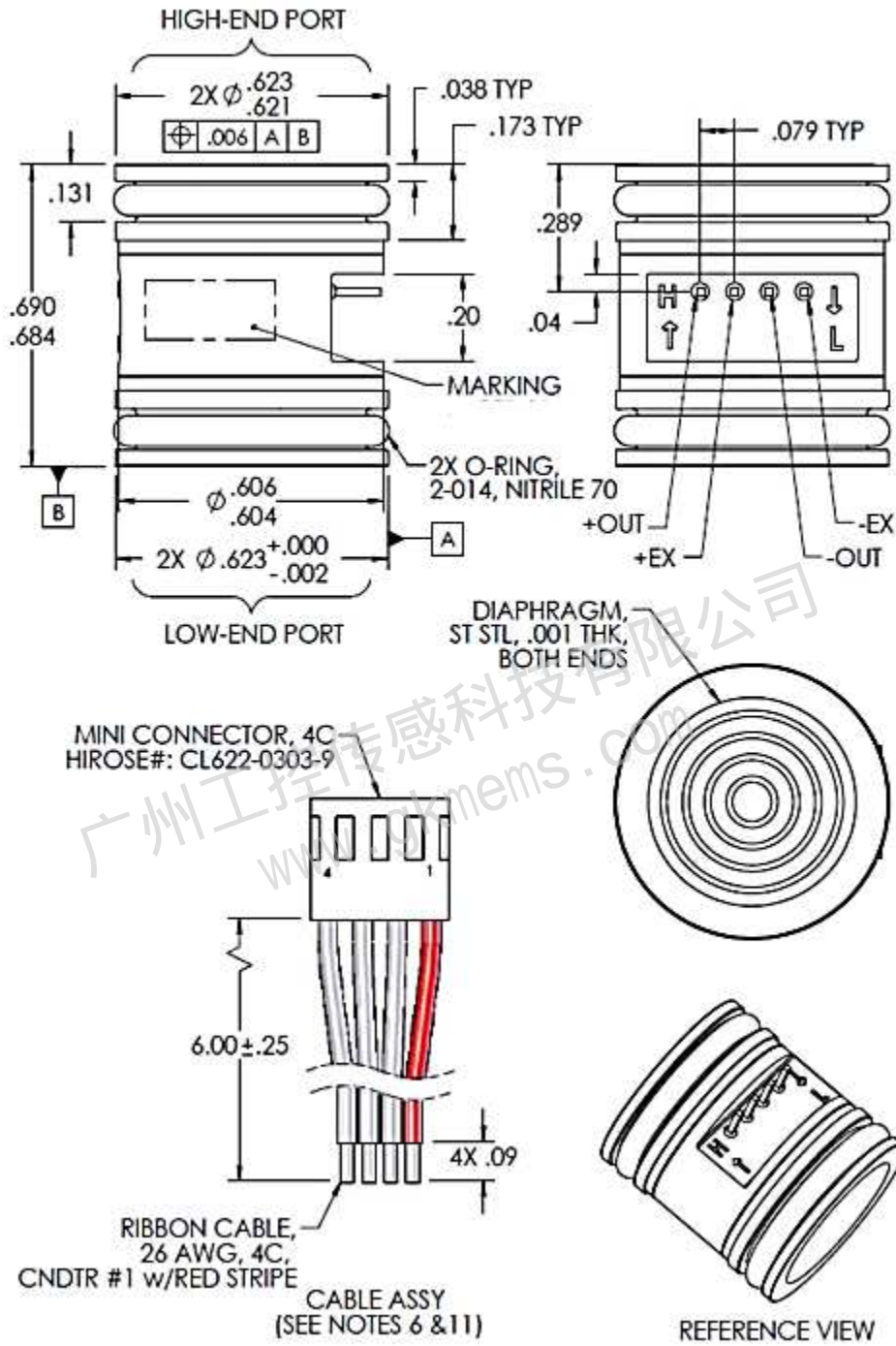

DP86

Differential Pressure Sensor

Compensation Schematic

(Sensors can be compensated using the schematic to get improved performance. A calibration data sheet is included with each unit that provides measured values along with resistor values that will achieve the calculated compensated performance.)

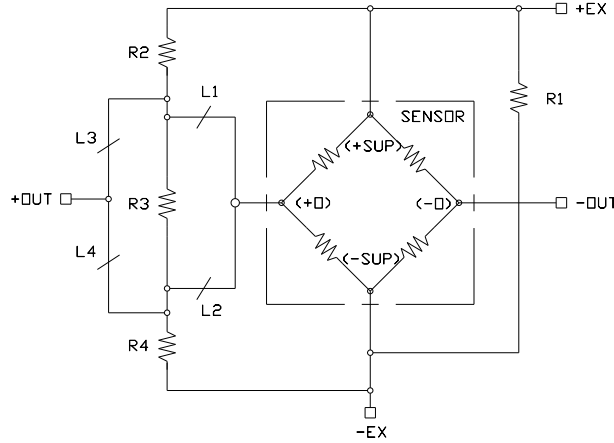

Ordering Information

Part Number
DP86 - 030D

Pressure Range [PSI]

001	1 PSI
005	5 PSI
015	15 PSI
030	30 PSI
050	50 PSI
100	100 PSI
300	300 PSI
500	500 PSI

Pressure Type

D Differential

广州工控传感科技有限公司

电话: 400-822-6658

邮箱: gzgk@foxmail.com

网址: www.gkmems.com

地址: 广州市天河区珠江西路15号16层